



**FERGUSON
BEAUREGARD™**
New Intelligence In Problem Solving™

A **DOVER**™ COMPANY

www.fergusonbeauregard.com

*i*Chem

Solar Chemical Injection System

Operator's Manual

Revision: 1

Revision Date: October 3, 2011



Better **People** | Better **Products** | Better **Performance**

2913 Specialty Drive • P.O. Box 130158 • Tyler, TX 75713-0158 • Phone: 903-561-4851 • Fax: 903-561-6567



**FERGUSON
BEAUREGARD™**

New Intelligence In Problem Solving™

iChem Operator's Manual

A **DOVER** COMPANY

www.fergusonbeauregard.com

Revision 1

Page 2 of 22

The Ferguson Beauregard iChem and manuals are Copyright © 2007-2011 by Ferguson Beauregard. All rights reserved. The iChem and iChem Installation and Operation's Manual are the property of Ferguson Beauregard and are not intended for public distribution.

All trade names or registered trademark names are the property of their respective owners and are referenced only herein without ownership implication.

Ferguson Beauregard

2913 Specialty Dr.

Tyler, TX 75707-1842

Phone: (903) 561-4851

Fax: (903) 561-6567

Email: staff@fbdover.com

Better **People** | Better **Products** | Better **Performance**

2913 Specialty Drive • P.O. Box 130158 • Tyler, TX 75713-0158 • Phone: 903-561-4851 • Fax: 903-561-6567



Table of Contents

DOCUMENT OVERVIEW.....	4
CHAPTER 1 INTRODUCTION	5
1.1 ICHM COMPONENTS	5
1.1.1 iChem Pump.....	5
1.1.2 Frame.....	5
1.1.3 Power System	5
1.1.4 Auto-Cycle Intelligent Controller.....	6
CHAPTER 2 PRE-FABRICATION.....	7
2.1 A-FRAME ASSEMBLY.....	7
2.2 COMPONENT MOUNTING.....	11
2.2.1 Battery Enclosure Mounting	11
2.2.2 Electronic Controller Mounting.....	11
2.2.3 Chemical Pump Mounting.....	12
2.2.4 Solar Panel Mounting	13
2.2.5 System Wiring.....	13
CHAPTER 3 ON SITE INSTALLATION	14
3.1 PLUMBING.....	14
3.2 PERFORMING A CHEMICAL INJECTION RATE TEST.....	15
3.2.1 Put the controller in Timer mode and prevent pump from cycling.....	15
3.2.2 Fill the chemical sight glass.....	15
3.2.3 Input test parameters to iChem controls and set pump cycle times.....	16
3.2.4 Reopen the chemical line and turn the pump on.....	16
CHAPTER 4 ICHM CONTROLS	17
4.1 ACTIVATE TIMER MODE	17
4.2 CHECK BATTERY CHARGE	17
4.3 SET UP PUMP OPERATION PARAMETERS	18
CHAPTER 5 APPENDIX A: CONTROLLER WIRING.....	19
5.1 WIRING DIAGRAM.....	19
5.2 MOTOR CONTROLLER SETTINGS.....	20
CHAPTER 6 APPENDIX B: TROUBLESHOOTING	21
CHAPTER 7 APPENDIX C: ICHM SITE SURVEY	22



Document Overview

- Chapter 1** **Introduction:** Provides an overview of the iChem Chemical Injection System, its components and functional capabilities.

- Chapter 2** **Pre-Fabrication:** Provides assembly instructions for the iChem system prior to delivering the unit to the well site.

- Chapter 3** **On Site Installation:** Provides plumbing diagrams and instructions for performing an injection rate test

- Chapter 4** **iChem Controls:** Provides a functional description of the Keypad/Display Terminal menu.

- Chapter 5** **Appendix A: Controller Wiring:** Provides a listing of the factory wiring and settings for the controller box.

- Chapter 6** **Appendix B: Troubleshooting:** Provides a table for troubleshooting common problems.

- Chapter 7** **Appendix C: iChem Site Survey:** To be filled out prior to installation.



Chapter 1 Introduction

Chemical Pump reliability and consistency are of utmost importance to oil and gas producers. Unfortunately, many chemical injection systems do not deliver the desired results. Ferguson Beauregard launched a joint engineering effort with our sister companies; Blackmer and Neptune, part of Dover's Pumps Solutions Group. That effort has resulted in the iChem, an innovative solar-powered chemical injection system with a superior pump design. iChem can deliver consistent, accurate injection rates for wells up to 1,200 psi. This advanced system was engineered to meet the needs voiced by our industry:

- Reduce Field Service and Maintenance Downtime
- Eliminate Chemical Loss Due to Leaks
- Precise and Consistent Injection Rates at Various Pressures

The Benefits:

- Decreased Maintenance
- Protect against Chemical Leaks
- Reliable Dosing Rates

1.1 iChem Components

- Neptune Solar Panel Operated Pump
- Ferguson Beauregard Auto-Cycle Intelligent Controller
- Power System
- A-Frame Assembly

1.1.1 iChem Pump

The chemical pump is designed with hydraulically balanced diaphragm technology for durability. Its 316SS and Teflon coated "wet end" is designed to handle a wide variety of chemicals for many applications and the attached brushless motor allows for highly consistent chemical dosing. A separate manual was included in the system packaging for the chemical pump itself. Any issues specifically concerning the chemical pump can be found there.

1.1.2 Frame

The A-frame is designed to hold all the components included in the iChem system. The A-Frame allows the user to complete most of the prep work (pre-fabrication) in a central office before transporting it to the well site, greatly reducing on-site installation time. It is also easily transportable and foldable if necessary.

1.1.3 Power System

The iChem power system typically includes a 12V, 100Ah battery in a lockable enclosure and a 50W or 80W solar panel depending on well site conditions such as injection pressure, daily chemical injection rate, available sunlight in region, and more. Larger power systems can be designed for special needs if necessary.



1.1.4 Auto-Cycle Intelligent Controller

The Auto-Cycle Intelligent Controller (ACiC) employs a liquid crystal display (LCD) with keypad interface for highly accurate settings. The controls operate the pump via intermittent ON and OFF phases that can be defined down to the second to inject the exact amount of chemical the well needs. To aid in quickly and accurately setting the ON and OFF cycle times to inject chemical at the desired rate, an on-board calculation routine is included in the control software to be used when performing a typical rate test (refer to section 3.2). The controller also provides system data such as battery voltage, casing pressure (if pressure transducer is installed), and more to monitor the well site and ensure the iChem system is working properly. The system comes with the optional feature of remotely monitoring the system data and controlling pump control settings with an add-on.



Chapter 2 Pre-Fabrication

Prior to delivering the system to the well site for installation, it is recommended that pre-fabrication assembly occur in a sheltered central office or location. The system can then be transported via truck to the installation site where the final installation steps can be performed. The pre-fabrication assembly work includes assembling the A-frame, mounting the system components, and gathering the tools and equipment needed for installation.

2.1 A-Frame Assembly

The A-frame components will arrive disassembled with the pieces illustrated in Figure 2.1 and Table 2.1.

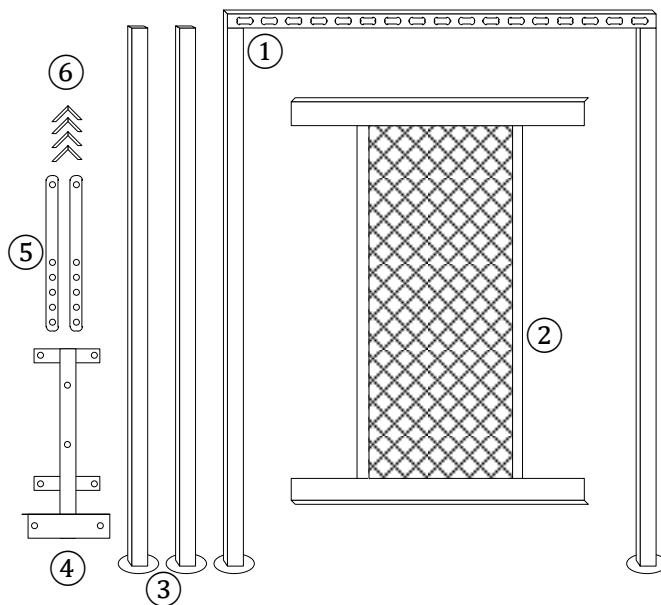

No.	Component	Qty
①	Primary Frame Support	1
②	Frame Platform	1
③	Secondary Frame Support	2
④	Controller Stem	1
⑤	Solar Panel Extender	2
⑥	Solar Panel Bracket	4
⑦	Bolt Kit (not pictured)	1

Table 2.1: A-Frame Component List

Figure 2.1: A-Frame Component Identification

1. Hold the Primary Frame Support ① upright so that the foot pads rest flat on the ground.
2. Slide the Secondary Frame Supports ③ into the slot at the top of the Primary Frame Support so that the securing holes line up as shown in Figure 2.2.
3. Secure each support with (1) ¼"x2½" bolt, (2) ¼" spacers, and (1) ¼" hex nut. Do not tighten.

! Do not tighten any of the bolts until Step 7.



Figure 2.2: A-Frame Support Assembly

4. Position the Frame Platform (2) between the Primary Frame Support (1) with the flat surface facing up as shown in Figure 2.3.
5. Secure each side of the Frame Platform (2) to the lower mounting holes on the Primary Frame Support (1) using (1) 1/4"x2 1/2" bolt, (2) 1/4" spacers, and (1) 1/4" hex nut. Do not tighten.



Figure 2.3: Frame Platform Assembly

6. Swivel the Frame Platform (2) up between the Secondary Frame Supports (3) and secure each support to the platform using (1) 1/4"x2 1/2" bolt, (2) 1/4" spacers, and (1) 1/4" hex nut.
7. Tighten all 6 bolts ensuring that the foot pads rest evenly on the ground as shown in Figure 2.4.
8. Attach the outer most of the 5 adjustment holes on the Solar Panel Extenders (5) to the upper mounting holes on the Secondary Frame Support (3) as shown in Figure 2.5 using (2) 5/16"x3/4" bolts, (2) 5/16".



Figure 2.4: Completed Platform

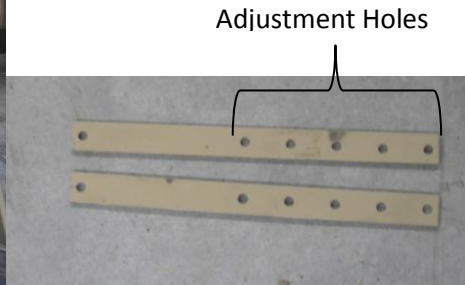
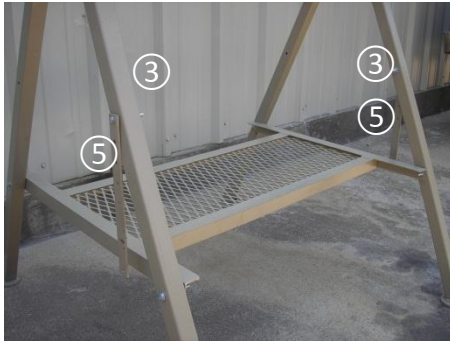

Figure 2.5: Solar Panel Extenders

9. Attach a Solar Panel Bracket ⑥ to each of the Solar Panel Extenders ⑤ mounting holes as shown in Figure 2.6 using (1) ¼"x¾" bolt and (1) ¼" hex nut. Do not tighten.

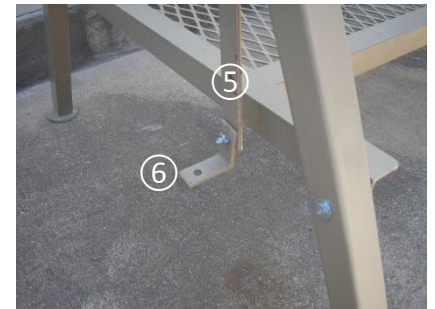

Figure 2.6: Solar Panel Extended Brackets



10. Attach (2) Solar Panel Brackets (6) to each side of the top of the Primary Frame Support (1) mounting holes as shown in Figure 2.8 using (1) ¼"x¾" bolt and (1) ¼" hex nut. Do not tighten.



Figure 2.8: Solar Panel Brackets

11. Mount the Controller Stem (4) to the flat side of the cross brace on the Primary Frame Support (1) as shown in Figure 2.7 using (2) 5/16"x3/4" bolts, (2) 5/16" spacers, (2) 5/16" lock washers, and (2) 5/16" hex nuts.
12. The A-Frame Assembly should now be similar to the frame shown in Figure 2.9.

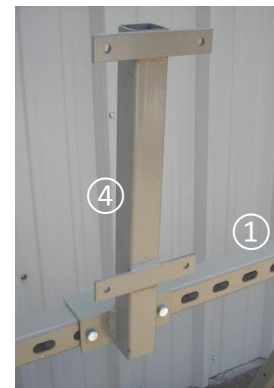

Figure 2.7: Controller Stem Assembly



Figure 2.9: Completed A-Frame Assembly



2.2 Component Mounting

Once the frame is constructed, the system components can then be mounted to it. These components include the solar panel, battery with enclosure, control box, and chemical pump. Other components or different quantities may be included for special install packages.

2.2.1 Battery Enclosure Mounting

1. Place the empty Battery enclosure on the A-Frame Platform as shown in Figure 2.10. Position the cord grip insertion holes facing inward toward the center of the frame.
2. Bolt down only 2 opposite corners of the enclosure using (2) ¼"x¾" bolts, (2) ¼" washers, (2) ¼" fender washers, (2) ¼" lock washers, and two (2) ¼" hex nuts.

2.2.2 Electronic Controller Mounting

The control box has a conduit fitting on the underside, a separate PVC flex conduit, and wires curled up inside the box. There will be two (2) sets of curled wires of four (4) foot length. One set contains five (5) wires while the other contains three (3).

1. Feed both sets of wires together through the conduit fitting and through the PVC flex conduit as shown in Figure 2.11.
2. Attach the controller enclosure to the controller stem using (4) ¼" x ¾" bolts and (4) ¼" lock washers.

! *Ensure the bolts connecting the control stem are tight.*

i *The controller may be hoisted to the controller stem or the stem may be removed and reattached after attaching the controller.*



Figure 2.10: Battery Enclosure Mounting



Figure 2.11: Electronic Controller Box



2.2.3 Chemical Pump Mounting

1. Mount the conduit fitting from the electronic controller to the junction box on the chemical pump and feed the wires through.



Figure 2.12: Chemical Pump Conduit Fitting

2. The junction box contains two (2) wire connectors, one a set of five (5) and the other of three (3). Using a small flathead screw driver, connect each free wire from the control box to the corresponding wire in the wire connector in the junction box. Press these back into the junction box and close the lid securely.

! Ensure the connecting wires are the same color and size.

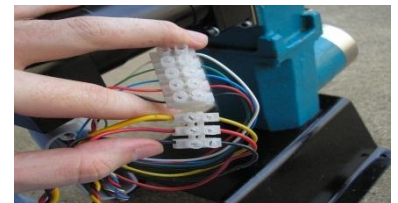

Figure 2.13: Chemical Pump Wiring

3. Place the chemical pump on the frame platform. Orient it as needed depending on the position of the chemical tank or the layout of the site.

! Ensure sure the two check valves on the front 316SS diaphragm head extend beyond the edge of the base. When positioned correctly, the front two holes on the pump stand will not be able to be bolted to the frame platform.

4. Use (2) ¼" x ¾" bolts, (2) ¼" washers, (2) ¼" fender washers, (2) ¼" lock washers, and (2) ¼" hex nuts to secure the (2) rear pump stand holes to the frame platform.

i If the pump must be within the containment pool, the length of conduit should allow the pump to reach comfortably with the frame positioned beside the pool. The control box stem can be repositioned to the edge of the Primary Frame Support to allow greater reach.



Figure 2.14: Chemical Pump Mounting



2.2.4 Solar Panel Mounting

1. Mount the solar panel to the Solar Panel Brackets using (4) ¼"x¾" hex head bolts, (4) ¼" washers, and (4) ¼" hex nuts.



If desired, the L-brackets may be mounted to the solar panel first before mounting to the frame.



2.2.5 System Wiring

Once the components are mounted, they can then be interconnected.

1. Feed the battery wires from the charge regulator in the battery box up to the control box.
2. Inside the control box will be a black motor controller as shown below. Connect the white battery wire to share the connection labeled V IN with relay and the black battery wire to the connection labeled GND.
3. Feed the solar panel wires to the battery box and connect to the solar charge regulator inside.
4. Connect the battery to the charge regulator and place inside the battery box.



Figure 2.15: Controller Wiring



Chapter 3 On Site Installation

3.1 Plumbing

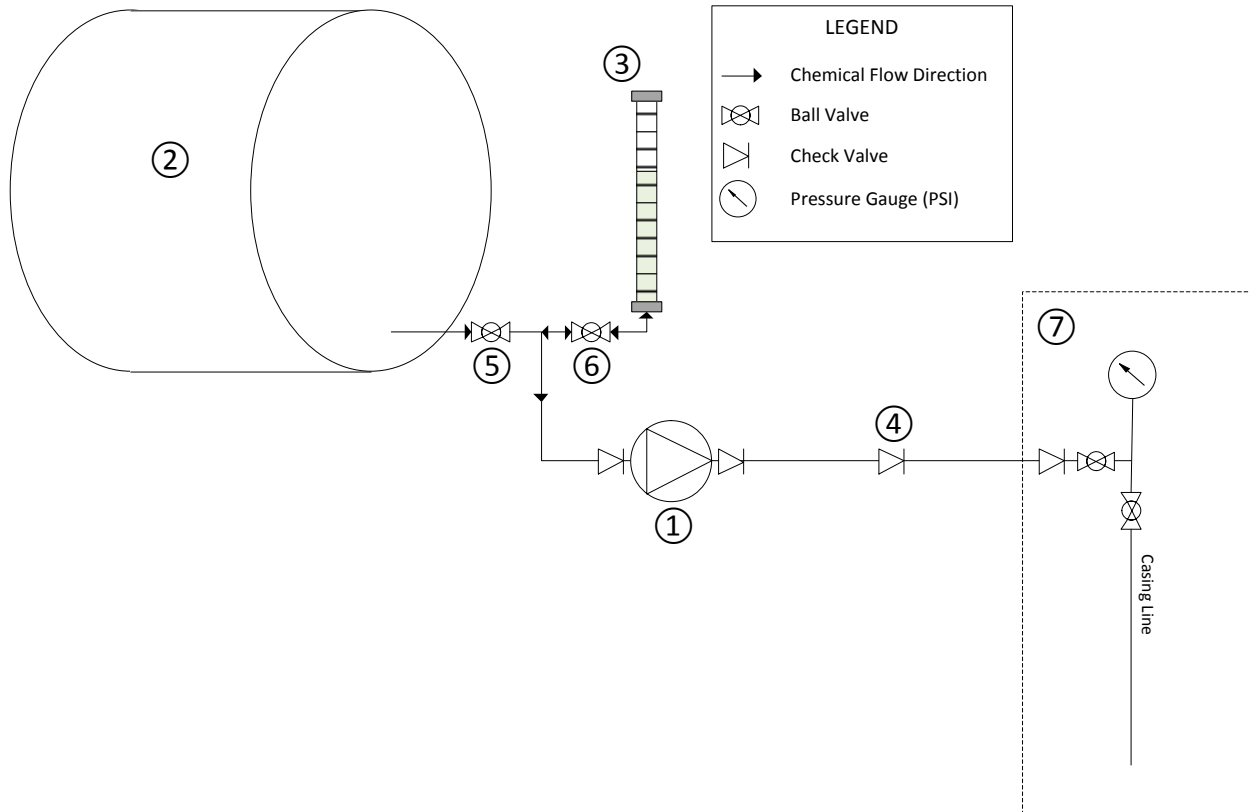

Figure 3.1: Chemical Injection Pump Plumbing Diagram

No.	Component
①	iChem Pump
②	Chemical Tank
③	Chemical Sight Glass
④	Injection Point (Y-Check Valve)
⑤	Tank Valve
⑥	Sight Glass Valve
⑦	Well Head

Table 3.1: Chemical Injection Pump
Component Identification



3.2 Performing a Chemical Injection Rate Test

Performing an injection rate test is necessary to set the pump cycle times correctly.

The test should be performed:

- Following installation
- After relocating a pump to a new well head
- Changing injection chemicals
- After adjusting or replacing any components on the pump or plumbing system.

It can only be performed after the iChem system is fully installed and powered up, and the injection line is primed. Refer to Figure 3.1 to follow the parts and numbers used in the instructions below.

3.2.1 Put the controller in Timer mode and prevent pump from cycling.

1. To ensure controls are set to Timer mode, on the main menu press the **SYS (F3)** key. Navigate to **CONTROL OPTIONS** and set **CONTROL MODE** to Timer.
2. From the main menu, press the **STUP (F4)** key and scroll to **SET UP PUMP**. Press **ENTER**.
3. Set **PUMP TEST MODE** to YES to put the pump in an indefinite Off cycle until it is time to perform a rate test.

3.2.2 Fill the chemical sight glass.

1. With the pump off, close the sight glass valve ⑥ and open the tank valve ⑤.
2. Slowly open the sight glass valve ⑥ and let the chemical rise to the highest visible notch on the sight glass ③.
3. Immediately close the sight glass valve ⑥. Do not fill above this notch.
4. Visibly mark the notch so as to not forget it.
5. With the sight glass valve ⑥ closed, fully close the tank valve ⑤.
6. Open the sight glass valve ⑥ to allow the pump to only pull chemical from the sight glass and not the chemical tank.



3.2.3 Input test parameters to iChem controls and set pump cycle times.

1. On the main menu of the iChem controller, press the **STUP (F4)** and scroll down to and enter **SET UP PUMP**.
2. Set **TEST TIME** for the amount of time the pump will run in the rate test.

i For highest accuracy it is best to set a time long enough to allow the pump to drain most of the chemical from the sight glass, without completely emptying the sight glass. Set **TEST TIME** to 10s if you are unsure.

! For larger sight glasses, do not exceed 60s.

3. Scroll down to and set **PUMP TEST ON** to YES. This will cause the pump to cycle on for the amount of time specified in **TEST TIME**. The chemical in the sight glass ③ should begin dropping.
4. When the pump ① turns off, visibly mark the new level of the chemical in the sight glass ③.
5. Count the number of notches between the two marked notches and record that number in **TICKS DROPPED** on the controller.

i If the chemical drains completely out of the sight glass ③, stop the test, refill the sight glass ③, and decrease the **TEST LENGTH** before restarting the test.

6. Set the sight glass graduation (**Qt. per Day** or **Gal per Hr.** based on a one minute test) as labeled on the sight glass ③ in the controller's **GLASS GRD** setting.
7. Input the desired injection rate into **INJ RATE**.
8. Set the units of your desired injection rate in **INJ UNITS**.

i For example, to set the chemical pump to inject five gallons per day, set **INJ RATE** to 5 and **INJ UNITS** to Gal/Day.

9. Set the number of times the pump will cycle each 24 hour period in **CYCLES DAY**.
 - **CYCLES DAY** of 0001 will inject the chemical in one large batch each day.
 - **CYCLES DAY** of 9999 will inject the chemical in numerous small doses spread evenly throughout the day.
10. Return **PUMP TEST MODE** back to NO.
11. Press the **MENU/ESC** button on the keypad to return to the previous screen.
12. Scroll to **SAVE CYCLE TIMES** and press **ENTER** on the keypad.

3.2.4 Reopen the chemical line and turn the pump on.

1. Close the sight glass valve ⑥ and open the tank valve ⑤ to allow chemical flow only from the chemical tank ② to the pump ①.
2. The pump is now ready to begin injecting chemicals. Press the **ON** button on the keypad to start the cycle and begin pumping.



Chapter 4 iChem Controls

4.1 Activate TIMER MODE

When the system is first powered on, the controls will boot up in **MANUAL MODE** to prevent the pump from inadvertently turning on. In this mode, the **ON** and **OFF** buttons on the keypad must be used control the pump. In order to perform a rate test and cycle the pump, the controls must be in **TIMER MODE** which can be set from the main menu:

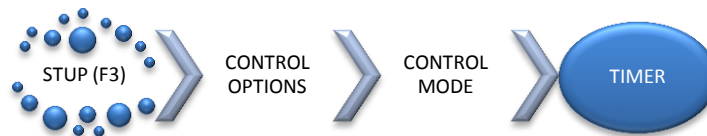

Use the arrow keys to navigate and press ENTER to enter each option. **CONTROL MODE** will initially be listed as MANUAL. With the cursor on CONTROL MODE, press ENTER and use the right arrow key to change from MANUAL to TIMER then press ENTER again. You can now return to the main menu and use TIMER features.

4.2 Check Battery Charge

To check battery voltage to determine its charge level, simply navigate the following menu path from the main menu:



The voltage will be listed there. For a 12V battery, a full charge typically corresponds to read around 13.4V.



4.3 Set Up Pump Operation Parameters

To perform a rate test to have the controls calculate the necessary On and Off cycle times to inject a desired amount of chemical, refer to 3.2.2 Performing a Chemical Injection Rate Test. As a reminder, to navigate to the pump setup menu from the main menu:

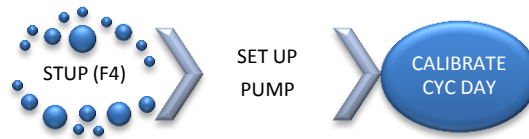

Here you can find and change the following parameters/options:

- **PUMP TEST MODEL:** Puts the pump in an extended Off cycle until the user either changes it back to NO, or changes **PUMP TEST ON** to YES. **PUMP TEST MODEL** must be set to YES to perform a rate test and must be changed back to NO before the pump can cycle as desired.
- **TEST TIME:** The amount of time the pump will run during a rate test when **PUMP TEST ON** is changed to YES.
- **TICKS DROPPED:** The number of graduation marks that the chemical dropped in the sight glass during a rate test.
- **GLASS GRD:** Glass Graduation sets the calibration method of the sight glass installed on the chemical tanks to Quarts/Day per 1 Minute Test or Gallons/Hour per 1 Minute Test as indicated on the sight glass.
- **INJ RATE:** The numerical amount of chemical the pump will inject. It must correspond with **INJ UNITS** as well.
- **INJ UNITS:** Sets the units in which the **INJ RATE** will be measured **INJ UNITS** can be set as QT PR DAY, GAL PR DAY, or GAL PR HR. For example, if **INJ RATE** is set to 4 and **INJ UNITS** is set to QT PR DAY, the pump will inject 4 quarts per day.
- **CYCLES DAY:** This is the number of times the pump will cycle each day based on its abilities. To inject one large dose each day, set to 0001. To inject multiple small doses, set to 9999.
- **PUMP TEST ON:** While PUMP **TEST MODE** is YES, **PUMP TEST ON** will turn the pump on for the amount of time listed in **TEST TIME** for the purposes of performing a rate test.



Chapter 5 Appendix A: Controller Wiring

5.1 Wiring Diagram

The wiring inside the controller should not require any attention with the exception of the battery leads in section 2.2.5. However, if the iChem system is not operating properly and troubleshooting suggests the problem is a wiring issue or a component needs to be replaced, consult the following wiring diagrams to ensure all wires are in their proper place.

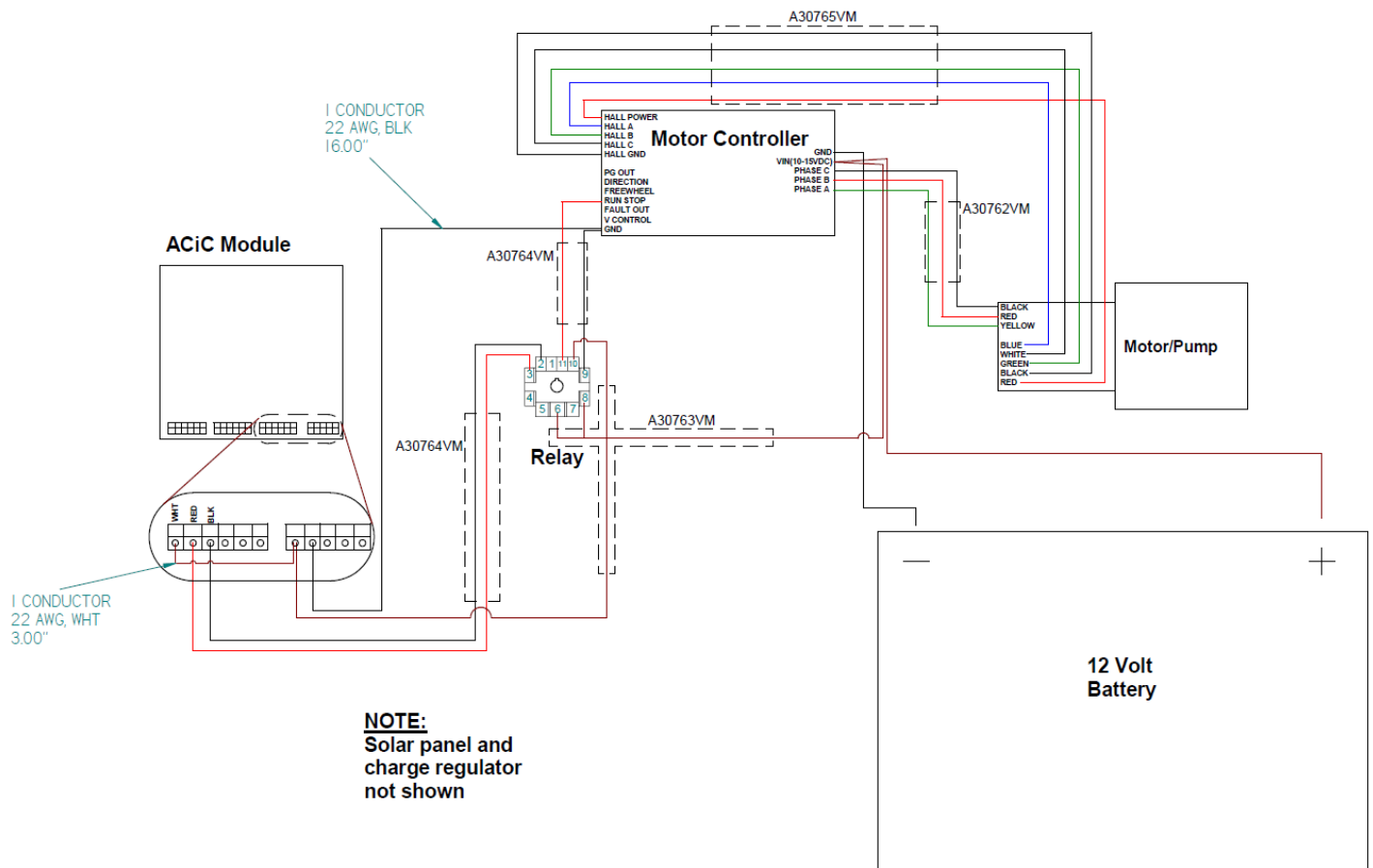

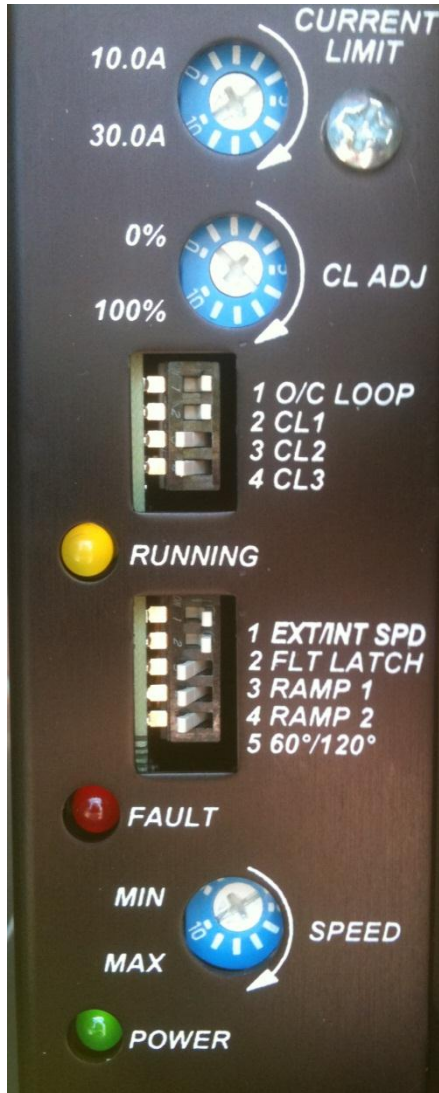

5.2 Motor Controller Settings

As with the controller enclosure wiring, the motor controller settings should not need to be altered. However, if the iChem is not performing correctly and troubleshooting suggests the motor controller settings are incorrect, consult the following controller settings to ensure the knobs and dipswitches match up.

Dip Switch	State (On = Left)
1 O/C Loop	Off
2 CL1	Off
3 CL2	On
4 CL3	On

Dip Switch	State (On = Left)
1 EXT/INT SPD	Off
2 FLT LATCH	Off
3 RAMP 1	On
4 RAMP 2	On
5 60°/120°	On



Chapter 6 Appendix B: Troubleshooting

Symptom	Possible Cause	Solution
Pump/Controls do not receive power.	<ul style="list-style-type: none"> • Incorrect Wiring • Blown Fuse • Battery Discharged 	<ul style="list-style-type: none"> • Refer to section 2.2.5 for correct wiring. • Replace fuse in the battery enclosure. • Check battery level with a Multimeter Charge or replace battery as needed.
Rate test routine does not calculate cycle times	Control Mode is set to MANUAL.	Refer to section 3.2 to put set the Control Mode to TIMER.
Controls have power but pump does not operate.	<ul style="list-style-type: none"> • Incorrect Wiring • Battery Discharged • Injection pressure too high • Motor controller settings incorrect 	<ul style="list-style-type: none"> • Refer to section 2.2.5 for correct wiring. • Check battery level with a Multimeter Charge or replace battery as needed • Ensure injection pressure is less than the pump rating.
Pump stuck in ON phase	Faulty relay	Replace the controller relay.



Chapter 7 Appendix C: iChem Site Survey

Company/Customer: _____

Location: _____

Location Name: _____

Address Line 1: _____

Address Line 2: _____

City (Nearest): _____ State: _____

GPS coordinates (if available): range and township? _____

Contact Name & Number: _____

Site Preparation/Site Survey Notes:

- Determine the injection chemical and obtain MSDS.
 - Chemical Vendor: _____ Part No: _____
- Determine the well injection pressure. High: _____ Low: _____
- Determine the make and model of any existing pump on site. _____
- Determine the desired daily injection rate. If the site has an existing pump, determine its set rate prior to disconnecting. _____
- List any rusted pipes and fittings at the chemical tank to replace with stainless steel equivalents.

- Is there an existing sight glass OR is the existing sight glass leaking or damaged (circle one)? Yes / No(damaged)
- How often does the chemical tank run empty? _____
- How long does it typically take to get the chemical tank refilled? _____

Site Survey performed by: _____ Date _____